



DC Voltage, 3 or 4 Wire, NPN, Connector Types

A range of DC voltage inductive proximity sensors each containing oscillator, amplifier and output circuitry. Housed in cylindrical bodies, incorporating a standard cable connector, they are particularly easy to install and adjust.

The three wire versions (type E) provide normally open (NO) type output operation whilst the four wire types (A) provide both normally open *and* normally closed outputs (NO and NC). Each sensor is equipped with over-voltage, polarity reversal and output overload protection.

The range is particularly suitable for applications where a high degree of reliability is required.

Part Number	Sensing Range (Sn)	Housing Diameter	Standard Target	Type	Output Function	Continuous Load Current	Maximum Switching Frequency	Drawing Number
PS1-8GM50-E-V1	1mm	M8 x 1mm	8 x 8mm	Flush	N/O	200mA	1 KHz	11
PS2-8GM50-E-V1	2mm	M8 x 1mm	8 x 8mm	Non Flush	N/O	200mA	600Hz	12
PS2-12GM50-E-V1	2mm	M12 x 1mm	12 x 12mm	Flush	N/O	400mA	800Hz	13
PS2-12GM50-A-V1	2mm	M12 x 1mm	12 x 12mm	Flush	N/O + N/C	200mA	800Hz	13
PS4-12GM50-E-V1	4mm	M12 x 1mm	12 x 12mm	Non Flush	N/O	400mA	400Hz	14
PS4-12GM50-A-V1	4mm	M12 x 1mm	12 x 12mm	Non Flush	N/O + N/C	200mA	400Hz	14
PS5-18GM50-A-V1	5mm	M18 x 1mm	18 x 18mm	Flush	N/O + N/C	400mA	500Hz	15
PS8-18GM50-A-V1	8mm	M18 x 1mm	18 x 18mm	Non Flush	N/O + N/C	400mA	200Hz	16
PS10-30GM50-A-V1	10mm	M30 x 1.5mm	30 x 30mm	Flush	N/O + N/C	400mA	300Hz	17
PS15-30GM50-A-V1	15mm	M30 x 1.5mm	30 x 30mm	Non Flush	N/O + N/C	400mA	100Hz	18

General Specifications

Operational sensing range (Sa)	$0 < Sa < 0.81S_n$
Hysteresis	3% or less
Repeatability	0.02mm or less
Supply voltage	10 to 30V DC (10 % Ripple or less)
Current Consumption	10mA or less (A2 types 20mA or less)
Material	Nickel plated brass
Environmental protection	IP65

Wiring Diagrams

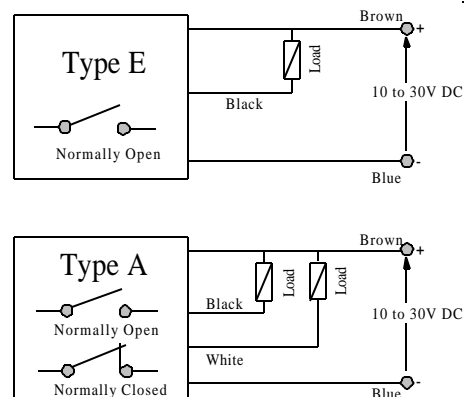

Notes

- (1) Standard Target. For comparison of sensing distance, a standard target is used as specified by IEC947-5-2. Larger sensing targets produce minor increases in sensing distance whilst smaller targets produce considerable reductions.
- (2) Non Flush Mounting. In order to achieve greater sensing distances non-flush types are available which have a less concentrated electromagnetic field. These types are not suitable for flush mounting due to the effects of the surrounding metal on the oscillator circuits.